

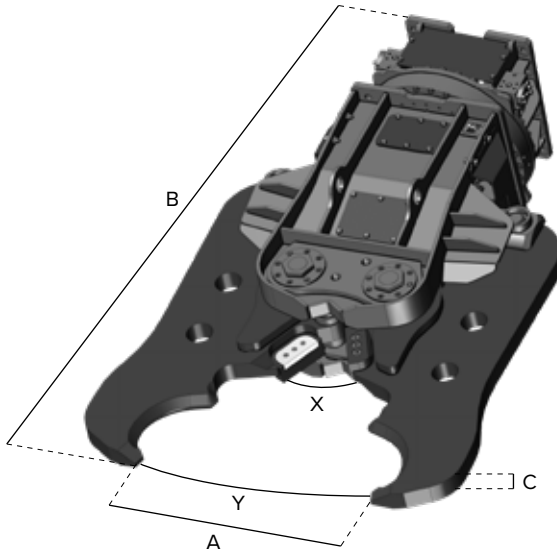







# HCC SERIES

Powerbooster Concrete Crushers



## POWERBOOSTER



CONCRETE CRUSHERS POWERBOOSTER			HCC-18P	HCC-24P	HCC-31P	HCC-46P
	Excavator class <sup>1</sup>	T.	16 – 23	24 – 32	33 – 40	41 – 56
	Weight	Kg.	1900	2500	3100	4680
	Cutter length	mm.	150	180	210	260
	Working pressure	Bar.	250	250	250	250
	Oil flow	L/min.	130/200	180/250	230/300	300/400
	Working pressure rotation	Bar.	140	140	140	180
	Oil flow rotation	L/min.	10/20	10/20	10/20	10/20
	A	mm.	850	1000	1130	1370
	B	mm.	2240	2360	2540	-
	C	mm.	60	80	90	-
	X	T.	360	390	430	-
	Y	T.	65	80	100	-
	Max. Diameter	mm.	35	45	50	-

<sup>1</sup> Recommended excavator/attachment combination

